

Senior Section

Activities

- ❖ History of our Link
- ❖ Game - numbers bingo
- ❖ Language - learn how to say a few phrases in Russian
- ❖ Look at straw craft and make your own 4 straw compass plait (examples available in resource box)
- ❖ Flag - make a Belarusian safety pin flag badge
- ❖ Food - prepare cook and eat Draniki
- ❖ Discover the Belarusian Ranger Promise Badge and promise (badge available in resource box)
- ❖ Dress a girl in Belarusian Guide uniform and look at the National Costume (available in resource box)
- ❖ Quiz - test your knowledge
- ❖ Find out how you could be part of a group visiting Belarus or hosting a Belarusian Ranger

History of our Link

Girlguiding Lincolnshire South is proud of its strong connections with Guiding in Belarus. Our link helped to support the development of their Guiding programme after the fall of communism in the country. It continues to grow year by year.

The link was established in 1992 when Lincolnshire South Guide Association hosted a small group from Minsk, Belarus at 'Poacher', Lincolnshire's International Guide and Scout Camp. This group was searching for a worthwhile Youth Association to replace the collapsed Pioneer Movement and came to find out about Scouting and Guiding. On departure, Lyudmila Zybina, their leader asked Phyll Sands if she would promise to take a party out to Minsk the following year. Phyll promised and sure enough the following April an official invitation arrived.

So, in 1993 a County group of Guides visited Minsk for two weeks. They camped in Gomel with children recovering from the Chernobyl disaster, and stayed in homes in Minsk.

Each year from 1994 to 2002 visits were made alternately from the two countries by groups of Guides and Senior Section. Visits to Lincolnshire included trips to the seaside, a novelty for those from a landlocked country, places of cultural interest and adventurous activities that couldn't be done back in Belarus. According to the girls visiting in 1998 it was a 'dream come true' with new friendships developing and guiding skills, crafts and ideas to take back and teach others in Minsk. Our visits to Belarus included reciprocal visits to places of cultural interest and the opportunity to be welcomed to a country very different to our own.

In 2002, the 10th Anniversary year of our link, thirteen girls and three leaders visited Minsk in late July/August followed in the September by a visit of four Minsk leaders to join our celebrations which included a visit by the Belarusian Ambassador to the UK.

In 2003 eleven of our Senior Section members and four Guiders attend the first International Camp held in Gomel. They took part in a ten day camp and stayed with families in home hospitality in Minsk for three days. Since then, alternate visits have continued incorporating elements of Girlguiding UK's Senior Section programme, in particular '4'.

Girlguiding Lincolnshire South supports the visits of our Belarusian friends with fundraising throughout the county. Without these generous donations, and support from Connect Youth International, the link would be unable to exist in the format it does today.

In 2018 another group from Lincolnshire South will be travelling to Minsk. Could you be part of this group?

Numbers

These are phonetic and written how they sound!

0
null

1
adeen

2
dva

3
tree

4
cheteeri

5
pyat

6
shest

7
siem

8
vosem

9
devyat

10
desyat

Try it...

- Play pairs and match the numbers in English and Russian using the grid below.
- Play bingo using the cards included as a starter. You can adapt the game for your Unit.
- Practise the numbers and then get into groups of the number called out by a leader.
- Sit on chairs in a circle and number everyone from one to ten in Russian. One person stands in the middle, calls out a number in English and those with that number must change seats before the person in the middle steals one. The person now without a seat stands in the centre and calls the next number.

dva	null	siem
chyeteeri	tree	shest
pyat	vosem	adeen

tree	desyat	pyat
devyat	siem	chyeteeri
shest	adeen	dva

devyat	desyat	null
adeen	vosem	pyat
tree	chyeteeri	shest

adeen	devyat	vosem
pyat	chyeteeri	siem
desyat	dva	null

Language

These are phonetic and written how they sound! The Russian language is written in Cyrillic and looks very different to English.

Very pleased to meet you	-	orchen preeyatna
Hello	-	zdrastvuytye (formal)
		privyet (familiar)
Good morning	-	dorbroye ootra
Good night	-	spacoini nochi
How are you?	-	Kak dyela
Good	-	harasho
What is your name?	-	kak vas zavoot
My name is ...	-	menya zavoot ...
How old are you?	-	scolka vam lyet?
Where do you live?	-	gudyer voy jevyotche
I live in ...	-	ya jevoo v ...
I'm English	-	ya anglichanka
Friend	-	droog
Yes	-	da
No	-	nyet
Who?	-	kto?
What?	-	shto?
I want	-	ya hachoo
Please / you are welcome	-	pajhalsta
Thank you	-	spaseba
Sorry / excuse me	-	eezvineetyeh
I don't understand	-	ya nye panimayoo
I don't know	-	ya nye znayoo
OK	-	lardna
I like	-	ya lubloo
A little bit	-	nyemnoshka
Tea	-	chy
Coffee	-	corfye
Sugar	-	saccar
Juice	-	sok
Wine	-	vino
What time is it?	-	kutory chass
How much?	-	skolka
Good bye	-	dasvidania
Until we meet again	-	davstriechee

Try it...

- Have a go at learning a few simple words. Try saying hello and introducing yourself... 'Privyet. Menya zavoot Olga!'
- Find out about the Cyrillic Russian alphabet. For starters, it was named after St Cyril.

Straw Craft

Straw weaving is one of the most loved folk arts and crafts in Belarus. Below are some decorative and practical examples.



From early times, Belarusian peasants were decorating their houses with intricate moving straw mobiles. Beautiful and useful objects of everyday life were made out of straw and used for the storage of goods and foods. Even Belarusian children's toys and dolls were often made out of straw.

Try it...

- Have a go at your own straw craft.
- Visit a place or person who makes an English version such as corn dollies or have a go at the examples which follow.

4-straw Compass Plait.

For a simple single loop favour (as shown below left), the 4-straw Compass Plait gives an attractive chunky weave.



Preparation

You will need:

- lengths of straw cut to a similar length
- cotton for tying
- ribbon for decoration

Straw needs to be soaked in water to soften it before use. Place your prepared lengths of straw in a trough full of water and weigh them down with something to keep them submerged. After half an hour, check that the cut end can be bent without cracking. When suitably pliable remove the straws from the water, drain off the excess moisture, and wrap in a damp towel. This will prevent your straws from drying out while you are working.

The plait can be decorated with a simple ribbon bow or a small sprig of dried flowers at the tied point.

Colours of ribbons have symbolic meanings:

WHITE is for purity

BROWN is for the earth

GREEN is for the germinating corn

GOLD is the ripened wheat

ORANGE is for the glowing sun

RED is for warmth, and also for the poppy in the corn field

BLUE is the colour of truth, and also the colour of the cornflower

To make a 4-straw Compass Plait

Step 1

Tie 4 straws tightly together under the heads with a clove hitch. Spread out into NESW. View from above with the heads under the central

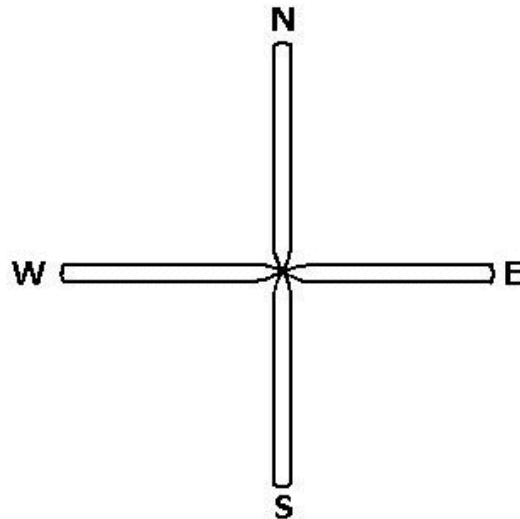

Step 2

Bring N down to lie by S. Take S up to where N was. It is important to keep the straws parallel as they cross over. Looking down on your plait it should look like this:

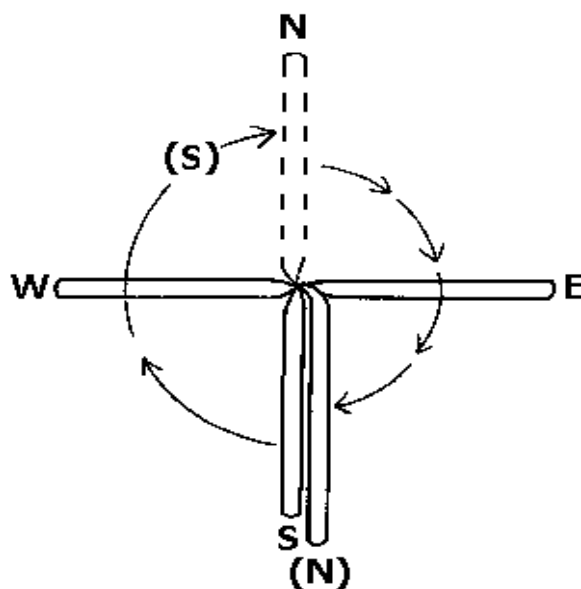

Step 3

In a similar move, bring E across to lie by W. Take W across to where E was:

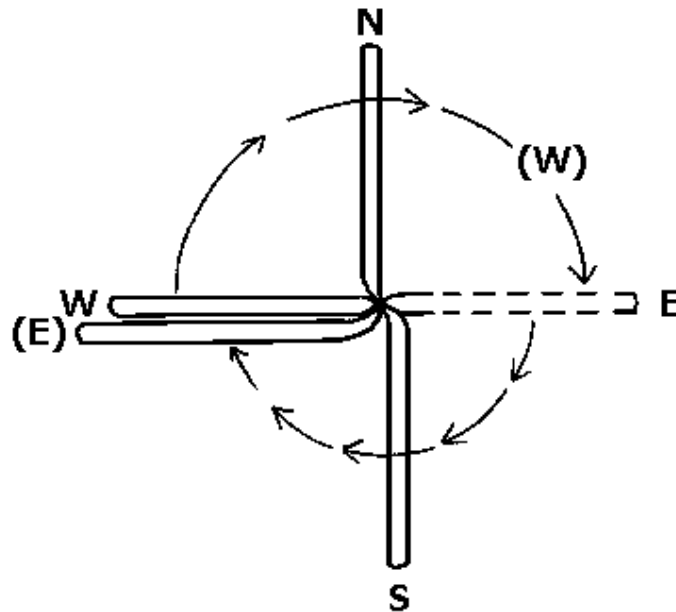

Step 4

Continue to plait in this way until you have about 8 cm of straw left.

Step 5

Bring the four straws up to meet each other, and tie firmly at the end of the plaited section with another clove hitch. Bring this tied end down to meet the other tie just under the heads -forming a loop of plaited straw as you do so. Tie the two together.

Step 6

Spread the wheat ears out between the wheat stalks and allow to dry flat, preferably under a weight. When dry you can clip the stalk ends decoratively and add a ribbon bow or a small sprig of dried flowers.

With a slightly longer length of plait you can make a fancier looped favour. When you have completed and tied off your length of plait, again leaving about 8 cm of straw, you can intertwine the plait into a double knot (see below). Next take the end straws round to the back and tie to the wheat ears. Again decorate with a ribbon, if you wish.

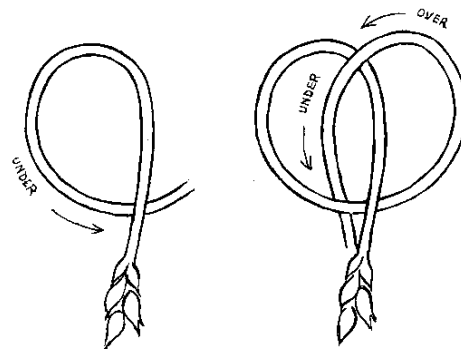

Flag



The Belarusian flag is made up of three colours: red, green and white. Each colour has its own meaning. Red symbolises Belarus' glorious past, green symbolises the future as well as hope, spring, revival, forests and fields. White represents purity and the decorative red and white pattern, thought to be a traditional peasant pattern, symbolises Belarus' rich cultural heritage and the unity of its people.

Try it...

- Make your own flag by colouring in a blank outline flag and attach to a stick or straw.
- Use shrink plastic to make flag badges and fridge magnets.
- Make a Belarusian safety pin flag badge with beads, 12 small safety pins and the colour chart below.

Colour Chart for Safety Pin Flag Badge

R	W	R	R	R	R	R	R	R	R	R	R	R
W	R	R	R	R	R	R	R	R	R	R	R	R
R	W	R	R	R	R	R	R	R	R	R	R	R
W	R	R	R	R	R	R	R	R	R	R	R	R
R	W	R	R	R	R	R	R	R	R	R	R	R
W	R	G	G	G	G	G	G	G	G	G	G	G
R	W	G	G	G	G	G	G	G	G	G	G	G
W	R	G	G	G	G	G	G	G	G	G	G	G
R	W	G	G	G	G	G	G	G	G	G	G	G

R - red bead

W - white bead

G - green bead

Food

Traditional cuisine includes: soups such as Borscht, made with beetroot and served hot with soured cream; stews; sausages and pies.

Belarus is well known for numerous recipes for potatoes, especially, Draniki, a potato pancake and Dracheny, a tasty potato dish with mushrooms. Mochanka is a thick soup mixed with lard accompanied by hot pancakes. Mushrooms and berries are favourite side dishes. Regional cooking is often based on potatoes.

Beef, chicken, pork and fish dishes are eaten together with vegetables such as cabbage, carrots, onions, mushrooms, peas, sauerkraut and tomatoes. Dairy products especially eggs and cottage cheese are also part of the Belarusian diet.

Favourite desserts are cakes, apple and berry fruit pies, and ice cream. Fruit is boiled and made into compote - often served at breakfast.

Bread, particularly rye bread, is a staple food and Buckwheat flour is used extensively in Belarusian cooking.

Mineral water is in abundant supply. A traditional drink is birch juice. Herb teas and coffee are popular - a favourite being chai (black tea). Alcoholic drinks are beer, kvas (a Russian malt beer) and vodka.

When joining a Belarusian family for a meal, which often lasts over a long evening, several toasts take place including those for good health (nazdarovia), love and the coming together of friends.

Belarusians are very proud of their hospitality but often have a very limited income, therefore the variety of food may not be as diverse as in this country, but good manners are essential and hosts would be offended if you refuse or leave any food or drink.

Try it...

- Act out being a guest in someone's home. Discuss your food likes and dislikes. How would you overcome this problem if staying in a Belarusian household? Consider how body language and facial expressions can offend other people.
- Try out the recipe below.
- Make non-alcoholic cocktails and drinks and practise toasting each other saying 'nazdarovia'.

Draniki

Ingredients (for 4 portions)

800g potatoes
1 onion
3 tablespoons plain flour
½ cup milk
1 egg
vegetable oil for frying
salt to taste

Method

1. Wash and peel potatoes. Grate them coarsely. Put them in a deep bowl. Add milk so that it covers the potatoes completely. It is done to prevent the potatoes from browning.



Images taken from <http://en.restoran.ru>

2. Peel the onions, slice them into half-rings and fry in pre-heated vegetable oil until transparent.
3. Drain the milk off the potatoes. Press the milk out of the potato mixture (draniki should be juicy, not wet). Add fried onions, flour, egg and salt. Mix thoroughly.
4. Heat vegetable oil in a frying pan. Put spoonfuls of the potato mixture into the frying pan and fry on both sides until a golden colour.

Guiding in Belarus



Guides are 11 - 15 years old
Rangers are 15 - 18 years old

Promise:

On my honour I promise that I will do my best:
To do my duty to my country, the Republic of Belarus,
To aspire to the highest spiritual ideals / God,
To help other people at all times,
To obey the Guide Law.

Law:

1. A Guide's honour is to be trusted.
2. A Guide is loyal, she respects and obeys her parents and her elders.
3. A Guide's duty is to be useful and help others.
4. A Guide is a friend to all and a sister to every other Guide.
5. A Guide is courteous.
6. A Guide is a friend to animals and takes care of nature.
7. A Guide has discipline and respects the interests of the Organisation.
8. A Guide smiles and is optimistic under all difficulties.
9. A Guide is thrifty but not stingy.
10. A Guide is pure in thought and deed.

Try it...

Copy a Belarusian Promise Badge onto paper - a different colour per group helps. Next copy the words of the Promise onto the back. Cut the paper into pieces and spread them out around the room.

Members of each group take it in turns to roll a dice. Each time a six is thrown, a piece of their coloured paper can be retrieved. Assemble all of the pieces of jigsaw together in the centre pages of a magazine.

When the jigsaw is complete, close the magazine and turn it over. When the magazine is opened carefully again, the Promise can be read.

Facts about Belarus

Status	A Republic, it gained independence from the former USSR in 1991 but it still has close links with former Russian Soviet (Russia).
Name	Means White Russia.
Capital	Minsk.
Area	207,600 sq km (just smaller than the UK) Consists of six regions: Brest, Gomel, Minsk, Grodno, Mogilev and Vitebsk.
Borders with	Latvia, Lithuania, Poland, Russia, Ukraine. It is landlocked.

The Glory Mound on the outskirts of Minsk is a memorial to the Soviet Army who liberated Belarus from the Germans in 1944.

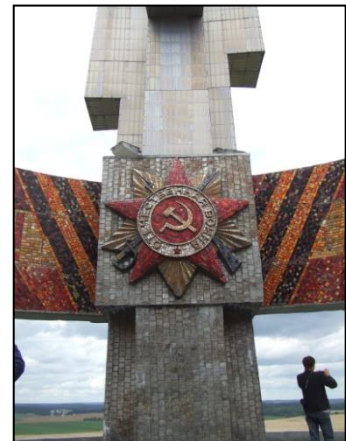

Weather	Very cold winters and warm summers.
Currency	Belarusian rouble.
Time	GMT + 2 hours.
Distance from London	1,162 miles or 1,870 kilometres. Minsk is 3 hours from London by air.
Landscape	Generally flat but with some hills. 36% of country is woodland. There are more than 20,000 rivers and 11,000 lakes. 45% of land is used for agriculture. 6% is specially protected nature reserves.
Religion	70% Russian Orthodox, 15 - 20% Catholic, 2% Protestant and small Jewish and Muslim communities.

Languages	Russian and Belarusian - Russian is the official language.
Environmental Issues	23% of Belarus, mainly the southern area of the country, was contaminated with radiation from the 1986 nuclear reactor accident at Chernobyl in northern Ukraine.
Education	Most high schools and universities teach exclusively in Russian although there are still many Belarusian Junior Schools. Belarusian is taught less frequently than Russian. Many students learn English at school.
Transport	Public transport in the capital city, Minsk, includes buses, trams, trolley buses and the underground. The underground is one of the most convenient ways of travelling and is renowned for its cleanliness and safety. The walls of the stations are decorated with painted murals.

Key facts in History

Pre-twentieth century ~ Belarus was an independent territory expanding and gaining land through many wars and invasions.

1917 ~ after revolutions, Soviet power was proclaimed in Belarus.

1918 ~ Belarus gained independence and the Belarusian People's Republic was formed.

1919 ~ The Belarusian Soviet Socialist Republic was created and remained in control for 72 years.

1941 ~ German troops invaded Belarus and the whole Republic was occupied.

During World War Two, one-in-four Belarusian's died. Almost all the cities were ruined and nearly 9000 villages were burned down.

1986 ~ Explosion at the Chernobyl nuclear power station in neighbouring Ukraine. 23% of Belarusian territory was contaminated with radiation.

1991 ~ Declaration of independence - the USSR ceased to exist.

1994 ~ Alexander Lukaschenko elected as first president of Belarus.

Quiz

1. What is the capital city of Belarus?
2. How many kilometres is Minsk from London?
3. How long does it take to get to Belarus from London?
4. Who do Guides and Rangers promise to do their duty to?
5. Can you say one Guide law?
6. Regional cooking in Belarus is often based on what vegetable?
7. What colours are found on the Belarusian flag?
8. What is the currency of Belarus?
9. Belarus is split up into regions. Can you name at least two of them?
10. Can you say the following in Russian:
Hello; goodbye; thank you; you are welcome?
11. When did the USSR cease to exist?
12. When did Lincolnshire South's link with Minsk start?